



Village Shires Community Association
3001 East Village Road
Holland, Pennsylvania 18966
Phone: 215-968-0618

BRIDLERIDGE RULES AND ARCHITECTURAL CONTROL

GUIDELINES

Date: March 31, 1983 Revised: March 31, 1985
Revised: February 24, 1986
Revised: July 7, 1986
Revised: December 17, 1986
Revised: March 7, 1988
Revised: August 21, 1991
Revised: November 20, 1991
Revised: January 15, 1992
Revised: April 15, 1992
Revised: May 19, 1993 Revised: June 16, 1993
Revised: September 22, 1993
Revised: November 17, 1993
Revised: March 16, 1994
Revised: September 21, 1994 (privacy dividers 14)
Revised: November 16, 1994 (pebbleboard M2b;
deck H5,6,7; patio N2e)
Revised: January 18, 1995 (privacy dividers 14)
Revised: May 17, 1995 (propane tank CC)
Revised: June 26, 1995
Revised: November 15, 1995 (bay window DO)
Revised: June 19, 1996 (paint information)
Revised: February 19, 1997

Revised: August 18, 1997
Revised: January 21, 1998
Revised: May 20, 1998 (window replacements EE2a)
Revised: April 28, 1999 (double hung windows GG)
Revised October 6, 1999 (Buten Paints now Duron)
Revised: April 11, 2002 (page 1,11,16)
Revised: April 21, 2004 (Bridleridge Document Created)
Revised: March 19, 2008 (sidewalks/walkways/steps)
Revised: January 21, 2010 (awnings)
Revised: February 21, 2013 (roof color)
Revised: August 10, 2014 (roof color)
Revised: February 18, 2016 (siding)
Revised: June 14, 2016 (roof maintenance)
Revised: June 14, 2016 (shed construction)
Revised: October 17, 2016 (steps/railings)
Revised: November 16, 2016 (shed construction)
Revised: July 19, 2018 (gate for post & rail fence)
Revised: October 10, 2023 (Shepherd's hooks, fence heights, string lights)
Revised: October 16, 2024 (fines for no ACC approval)

**BRIDLERIDGE RULES & ARCHITECTURAL GUIDELINES
INDEX**

- I. FOREWORD – Page 3
- II. HOMEOWNERS CAUTION – Page 3
- III. PROCESSING PROCEDURE – Page 4
- IV. APPEAL PROCEDURE – Page 4
- V. ARCHITECTURAL COMMITTEE RESOLUTION- Page 5

BRIDLERIDGE RULES, REGULATIONS AND ACC GUIDELINES

- 1. ANTENNAS – Page 6
- 2. ATTIC FANS AND VENTILATION – Page 6
- 3. AWNINGS – Page 6
- 4. BASKETBALL COURTS – Page 7
- 5. CLOTHES LINES AND CLOTHES TREES – Page 7
- 6. CONSTRUCTION, ALTERATIONS- Page 7
- 7. FENCES- Page 7 & 8 and drawing on page 9
- 8. FIREWOOD- Page 8
- 9. FRONT PORCHES –Page 8
- 10. KEROSENE HEATERS- Page 8
- 11. LANDSCAPING- Page 10
- 12. LATTICE- Page 10
- 13. LEASING OF DWELLING UNITS- Page 10
- 14. LIGHTING- Page 10
- 15. MOTOR VEHICLES- Page 10 & 11
- 16. NUISANCE- Page 11
- 17. PAINTING- Page 11
- 18. PARKING- Page 11 & 12
- 19. PATIOS, PATIO COVERS AND DECKS- Page 12
- 20. PET POLICY- Page 12
- 21. PROPANE TANK- Page 13
- 22. PROPERTY MAINTENANCE- Page 13
- 23. ROOF & ROOF MAINTENANCE- Page 13
- 24. SATELLITE DISHES- Page 13
- 25. SHEDS- Page 13 & 14
- 25d. STORAGE BINS (RUBBERMAID)- Page 15
- 26. SIDING- Page 15
- 27. SKYLIGHTS- Page 15
- 28. SIDEWALKS- Page 15
- 29. STEPS/RAILINGS- Page 15
- 30. SWING SETS, SLIDES, RECREATIONAL STRUCTURES, SPAS, POOLS- Page 15
- 31. TRASH- Page 16
- 32. WINDMILLS- Page 16
- 33. WINDOW FLOWER BOXES – Page 16
- 34. WINDOWS, DOORS AND SCREENS- Page 16
- 35. WINDOW AIR CONDITIONERS AND WINDOW FANS- Page 16
- 36. WOOD STOVES- Page 16

I. FOREWORD:

The architectural character of our community has been established by the architects and planners who originally designed Village Shires. The Architectural Control Committee (ACC) is responsible for preserving the architectural integrity of that design. It establishes architectural control standards and is responsible for informing all homeowners about the standards. Those standards are not intended to stifle the imagination or creative desires of our residents, but rather assure them that protective restrictions are in effect which will help maintain the appearance and value of their property. Duties of the Architectural Control Committee include:

- Informing homeowners that all visible changes to their property, including outside painting, must be approved in advance by the committee.
- Approval or disapproval of all visible exterior alterations to the homeowner's property. A request form must be submitted and ACC approval received in writing, by the homeowner before work on the change is started, except as noted in these guidelines.
- Developing architectural guidelines and standards and distributing them to all homeowners.
- Reviewing violations, attending hearings and implementation of fines to owners who fail to comply with ACC Rules and Guidelines.

II. HOMEOWNERS ARE CAUTIONED:

DO NOT begin any project without ACC approval. Any homeowner who begins a project without ACC approval will incur a \$250.00 non-refundable fine. You must wait for approval from the Architectural Control Committee as it *cannot* be assumed that your request will be approved.

DO NOT buy materials or enter into a binding contract for exterior alterations or changes until approval is received in writing from the Architectural Control Committee (ACC). **ALL ACC APPROVALS ARE GOOD FOR A MAXIMUM OF ONE (1) YEAR FROM DATE OF APPROVAL.** If a permit from the township is required, that too, should be obtained prior to signing a contract or purchasing materials. Send copy of the permit, when received, to the VSCA office to remain on file.

DO NOT patch the roof or install siding in an area of your unit without obtaining approval of the Architectural Control Committee. Generally, new roofing or siding materials will not match existing materials and the Architectural Control Committee may require that the entire exposed surface of the roof or the entire exterior wall where there is damage to the siding be replaced in order to assure the integrity of the architectural design of the building and to assure that the roof and the exterior walls present a uniform appearance.

Obtaining a municipal permit does not waive the need for ACC approval.

Approval of any project by the ACC does not waive the necessity of obtaining the required municipal permits. If Township permit is required, send a copy of permit, when received, to the VSCA office to remain on file.

Abiding by deed restrictions, such as not obstructing pedestrian easements, is the responsibility of the homeowner. All cost and damages incurred as a result of not complying with the restrictions will be borne by the homeowner.

Any violation of the ACC Guidelines shall cause the Association to enact the enforcement policy (request Enforcement Policy at VSCA office).

The ACC will not knowingly approve a project which is in violation of the municipal building or zoning codes.

Any structure to be built must be submitted to the township for building permits.

The township limits the coverage of the property to 45% impervious construction.

Your township taxes may be increased if a structure connected to the home is added.

III. PROCESSING PROCEDURE:

1. The ACC will consider only written requests using Permission Request Forms, obtainable from the Village Shires Community Association office (VSCA office) at 3001 East Village Road, Holland, PA 18966 (Clubhouse I).
2. The description of the project should include all information necessary for the ACC to take action. Necessary data would include, but is not limited to, the height, width, length, size, shape, color, location of the proposed improvement, and neighbor's signatures on the Neighbor Notification Form when needed. Photographs or sketches of similar completed projects would aid in the ACC's consideration. If the alteration affects the existing drainage pattern, the proposed drainage pattern must be included.
3. When Permission Request Forms are received by the VSCA office, they will be date stamped and reviewed for completion. If the ACC fails to reply to the applicant within 45 days from the date stamped, then the request is considered to have been approved. Certain requests may be forwarded to the Chairperson's Committee and the Board of Directors for final approval.

IV. APPEAL PROCEDURES:

1. If a proposal is rejected, the applicant is free to request that the ACC reconsider its position and is encouraged to present new or additional information which might clarify the request or demonstrate its acceptability.
2. If the applicant is not satisfied with the ACC's decision, an appeal may be made to the Grievance Committee (request Enforcement Policy from VSCA office).
3. For final appeal, a certified letter (return receipt requested), describing the proposed improvement should be sent to the Management office, to the attention of the President of the Board of Directors.

Variances to these guidelines will be considered by the ACC when a petition is presented and signed by a majority of the Bridleridge homeowners.

V. ARCHITECTURAL COMMITTEE RESOLUTION

Preamble and Preliminary Statement

The Article of Bridleridge Supplemental Declaration of Covenants and Restriction was duly recorded in the Bucks County Recorder of Deeds Office Book 2690 page 733 on August 7, 1986.

Section 2.01 (a) of the Bridleridge's Supplementary Declaration requires the consent of the Architectural Control Committee before any of the Bridleridge Unit Owners build any addition or structure or alter the height, area or color of any structure within the Bridleridge community.

Section 3.01 of the Bridleridge Supplementary Declaration provides the Association with enforcement authority pursuant to the community documents and law.

The buildings and structures within Bridleridge are aging and/or otherwise in need of repair and special attention of the Architectural Control Committee.

The Village Shires Community deems the following Bridleridge Rules, Regulations and ACC Guidelines (which are binding upon and limited to Bridleridge Units and Homeowners) to be for the common good of Village Shires Community in general and Bridleridge homeowners in particular.

BRIDLERIDGE RULES, REGULATIONS AND ACC GUIDELINES

1. ANTENNAS

Antennas are not allowed to be erected or maintained on any building or lot.

2. ATTIC FANS AND VENTILATORS

Attic fans and ventilators that come through the roof do not need ACC approval.

3. AWNINGS

1. Only lateral arm retractable awnings are permitted.
2. The purpose of awnings is to shade decks or patios only. No window awnings.
 - a. Owners are cautioned not to use barbecues under cover of awnings.
3. The retractable awning sunscreen material must be made of a cloth material such as canvas, mesh or comparable soft material. Rigid aluminum, vinyl or polyethylene shade materials are not permitted.
4. Only one Retractable Awning is permitted per home.
5. Side or Drop Arm Awnings are prohibited.
6. ACC Request Form must be submitted prior to the installation of the retractable awning. At a minimum, the ACC Request Form must include:
 - a. A detailed drawing of the installation location from the back, side and top of the retractable awning when fully open.
 - b. Installation measurements.
 - c. Brochure of the unit type/model with information on the manufacturer and installation company with insurance certificate.
 - d. Anchor/fastening system details.
 - e. A copy of the Northampton Township electrical permit (if awning is a powered model).
7. Retractable awnings must be installed on the rear or side of the house out of the site line of the street.
8. The color of the support system (frame) must be white or match the color of the shade material.
9. Solid colors only (see colors below);

Siding: White	Awning: Natural or cream
Siding: Sterling Gray	Awning: Cadet grey or slate gray
Siding: Autumn Yellow	Awning: Oyster or cream

There will be only one awning color per row of townhouse. The awning color selection will be made by the majority of townhouse owners in each building.

10. The size of the retractable awning may not exceed the width of the patio or deck.
11. The maximum height of the retractable awning shall not exceed 10 feet above the elevation of the patio or deck.
12. The retractable awning sunscreen material cannot drape around the perimeter more than 12 inches below the protective hood.
13. All retractable awnings must be retracted each evening at sundown and/or when not in use.
14. If the retractable awning or relevant fixtures are not in good working order or are allowed to degrade or to become unsightly, broken, faded, torn, moldy or tattered and are not replaced within (30) days after a written request by the VSCA, the VSCA will request the owner to remove the entire retractable awnings within (14) days or face a fine.
15. Under any circumstances related to the use or removal of retractable awning, the homeowner will be responsible for any damage to structure, to the exterior of the home, the adjoining properties, adjoining common elements and will be required to restore the structure, the exterior of the unit and/or the adjoining common elements to their original condition. If the unit owner fails to remove

the retractable awning or relevant fixtures or to restore the structure, exterior of the unit, adjoining properties and/or the adjoining common elements to their original condition within the time designated in the request letter from the VSCA, the unit owner shall be subject to fines, fees, and other penalties as permitted under the Maintenance Charges under the By-Laws of Article V.

16. All applications must be approved by ACC Committee and VSCA Executive Board.

4. BASKETBALL COURTS

Basketball courts of any type are not permitted.

5. CLOTHES LINES AND CLOTHES TREE

Clotheslines, clothes trees, and any type of structure used to hang clothes outside are not permitted.

6. CONSTRUCTION, ALTERATIONS

A. Before making any alterations, see the Village Shires Architectural Control Committee guidelines or specifications and requirements.

B. No building, fence, wall or other structure shall be commenced, erected or maintained on the Owner's lot, nor shall any exterior addition to or change (including change of external scheme) or alteration be made until the plans and specifications showing the nature, kind, shape height, materials, exterior colors, and location of same shall have been submitted on ACC Permission Request Forms, and approved, without condition, in writing, as to harmony of external design and location in relation to surrounding structures and topography by the Board of Directors of the Association, or by the Architectural Committee empowered by the Board of Directors to so act. In the event said Board, or its committee, fails to act upon such application within forty-five (45) days after said plans and specifications have been submitted to it, approval will be deemed to have been granted without conditions.

C. Township permits may be required and are the Homeowner's responsibility. If a Township Permit is required, please send a copy of it to the VSCA office to remain on file.

7. FENCES

A. Every effort will be made by the ACC to keep all fencing as harmonious as possible with the architectural character of the community.

B. ACC permission Request Forms must show location and the description of the type of fence.

C. ALL fences must have the approval of the ACC before installation is undertaken.

D. The types of fence that have been sanctioned for our development are

1. Board on board privacy fence

2. Post and rail, utilizing two (2) or three (3) rails.

Additional fence styles may be approved by petition through the ACC to the Board of Directors.

E. No fence will be approved if its installation will obstruct sight lines of vehicular traffic.

F. The ACC will not approve an application for the installation of any type of fence except the two (2) styles listed. Chain link or other galvanized metal fencing is specifically prohibited under any circumstances.

G. It is recommended that fences be set four (4) inches inside the property lines unless there is a pedestrian easement. If there is a pedestrian easement, four (4) feet in width, normally two (2) feet of the easement will be on each of the two (2) owner's property. Fences must be set in compliance with the individual deed restrictions, i.e. two (2) feet from the property line where there is a pedestrian easement.

H. Survey responsibility is the homeowners. If the fence is not positioned properly, the cost of removal and any damage caused thereby is the responsibility of the homeowner. (FYI, some certified surveying companies have offered discounts to groups of two (2) or more homeowners when the group has common boundaries).

I. All permits and/or licenses are the responsibility of the homeowner. If the township permit is required send a copy of the permit to the VSCA office, which will remain on file.

J. All fencing should have finished materials on both sides.

K. The fence will be unstained and unpainted and must remain that way. Only clear preservatives can be used on it.

L. Fences cannot extend beyond the front building line. This is a township regulation.

M. Owners in each building will select either one of the two types of fence, post and rail or board on board. The fence type selection will be made by the majority of the townhouse owners in each building, in writing. Once selected, the one type of fence will be the only type of fence authorized for that building.

1. **BOARD FENCES:** Board on board wood fences will be approved with the following limit: fencing will be limited to four (4) feet in height with the first ten (10) foot section extending out from each side of the building to be limited to five (5) feet in height. The fence will taper down to four (4) feet in the next two (2) feet of fence. The height must be uniform between posts, with alternating boards on each side of fence. (See Figure 1 drawing on page 9).

2. **POST AND RAILS:** A post and rail fence can be either two (2) or three (3) rails. The maximum height of the top rail will not exceed four (4) feet and post shall not exceed four (4) feet six (6) inches. Wire mesh, if used, will be of green plastic coated wire. The mesh shall be no smaller than 2" x 2-1/2". The mesh shall be on the inside of the fence and shall not extend above the top of the fence. Gate must match the post and rail design of either (2) or three (3) horizontal rail boards (see pictures below). If needed for added strength, max vertical boards three (3) as shown.



3. **PRIVACY DIVIDERS:** Interior townhouses are permitted to have privacy dividers if they meet the following criteria:

- a. The townhouses cannot have the extended utility room.
- b. Construction will be board on board and limited to one eight (8) foot section and cannot be more than five (5) feet high. The divider will follow the same requirements as the board on board fences (see figure 1). Board on board privacy dividers will be limited to a maximum height of five (5) feet, maximum length of eight (8) feet from each side. The top of the posts and fencing boards are to be flat, as per figure 1.

4. Poles & Posts

a. **Wooden posts are not permitted in the front or rear of the property, to hold lights or other items.**

b. **Shepherd's hooks are permitted to hold string lights per the following specifications: must be steel or aluminum, must not exceed a 1/2 inch in diameter, and must not exceed 8 feet in height from the ground, black in color and may be set in the ground or attached to the inside of the fence.**

8. FIREWOOD

- A. Firewood shall be stored in a storage frame on the back patio or back yard.
- B. Refrain from storing firewood against your home to prevent possible termite damage.

9. FRONT PORCHES

- A. Porches are not to be used for storage and/or trash.
- B. Trash, trashcans, household refuse, recyclable materials, paper goods, newspapers, recyclable containers and/or bags are not permitted to be stored on any front porch.
- C. Lawn mowers, rakes, shovels, lawn equipment, ladders, building materials, lumber and/or wood are not permitted to be stored on any front porch.
- D. Sports equipment, toys, pet cages, etc. are not permitted to be stored on any front porch.
- E. Bikes, mini bikes, wagons, and scooters may not be left overnight on any front porch.
- F. Patio and/or garden furniture are permitted on the front porch.
- G. Trash cans, bag, containers and recyclable containers are to be kept out of the sight line from the street; not to be visible from the street or stored on the front porch.

10. KEROSENE HEATERS

- A. ACC permits are not required for heaters.
- B. U.L. approvals are required for many insurance policies.
- C. TOWNHOUSES are not permitted to have outside storage of kerosene.
- D. Only (5) gallons of kerosene may be stored inside a house

FIGURE 1

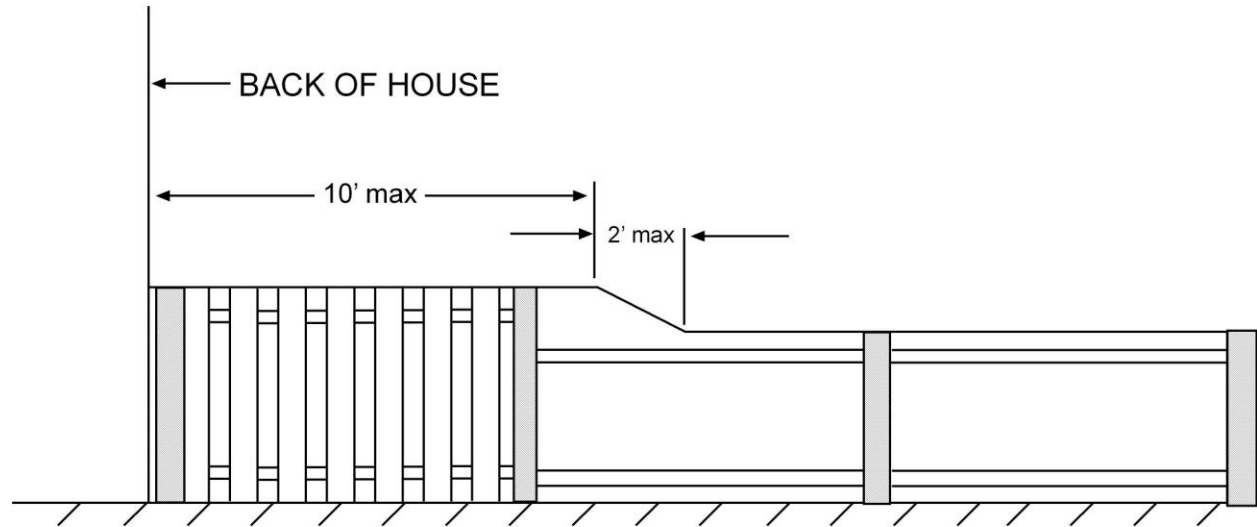

SIDE VIEW

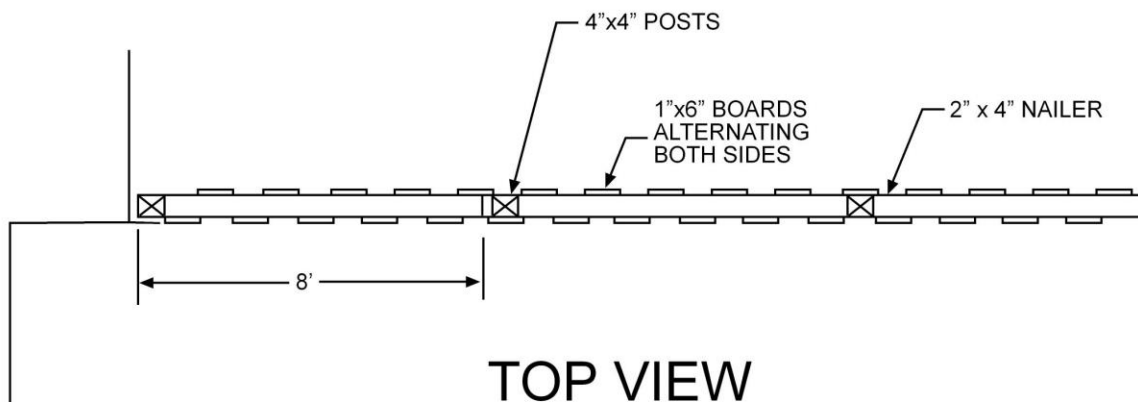

TOP VIEW

BOARD ON BOARD WOOD FENCES

11. LANDSCAPING

A. If more privacy is needed, there are many varied and beautiful landscaping techniques which may be employed. Landscaping work and plantings, in general do not require approval of ACC. If stones are used and the cumulative area of the stones exceeds hundred (100) square feet, then ACC approval is required.

B. Planting of trees, shrubs or hedges does not require approval of the ACC; however, care should be exercised in placement of such landscape so it does not interfere with your neighbor, intrude on their property, or restrict sight lines of vehicular traffic. Trees, hedges, shrubs which restrict sight of vehicular traffic must be cut back or removed.

C. Retaining walls and grading alterations which change the contour of earth and/or water drainage patterns must be submitted with complete details, including sketches for approval. (Flowerbeds that are less than one (1) foot high and do not affect drainage patterns are considered landscaping).

12. LATTICE

Lattice is not permitted anywhere in the community.

13. LEASING OF DWELLING UNITS

A. No Dwelling Unit Owner shall be permitted to lease his Dwelling Unit unless the dwelling unit owner has complied with the relevant provisions of the Declaration, Supplemental Declaration, the By-Laws and any applicable rules and regulations promulgated from time to time by the Association. All leases must be in writing for a term not to be less than one (1) year. All Lease forms must be approved by the Association. All leases shall provide that the lessee shall be subject in all respects to the provisions of the Declaration, Supplemental Declaration, the By-Laws and any applicable rules and regulations of the Association. Prior to the tenants moving in, the landlord must furnish the Association with the following:

1. Copy of a fully signed lease
2. Copy of fully signed Lease/Tenant Addendum; as approved by the Association
3. A \$50.00 processing fee made out to Village Shires.

Failure to comply with the lease rules will result in an initial fine of \$75.00 and continued non-compliance will result in additional fines as per the Bridleridge Enforcement Policy.

14. LIGHTING

A. Front entry porch lights must be lit at night. Exterior light photocells shall be maintained in working condition by homeowners.

B. Exterior lighting shall not be directed in such a manner as to create annoyance to your neighbor.

C. Exterior Decorative lighting such as string lights with clear bulbs may be hung in the rear of the property. Please refer to Wooden Posts/Shepherd's Hooks on page 8.

15. MOTOR VEHICLES

A. No motor vehicles, including but not limited to, mini-bikes, snowmobiles, ATVs, and motorcycles may be driven on the Common Grounds.

B. No Unit owner or tenant shall leave any non-operating vehicle or vehicle not having a valid inspection sticker, registration of vehicle, or license plate on or about the property of the Unit owner, neighbors, or the Village Shires Community Association.

C. Motor vehicles are not to be used for purposes of habitation; storage of goods, materials or equipment.

D. Occupants performing routine vehicle maintenance must complete the work within 24 hours.

E. The speed limit within Bridleridge is 15 miles per hour.

F. Unauthorized vehicles. Bridleridge is a multifamily residential district, zoning code R-3.

Parking of the following vehicles is prohibited and they are subject to being towed. The Unit owner and/or tenant who permitted the vehicle to remain there, will be liable for the cost of towing and storage of the vehicle; in addition to any fines.

1. Recreational Trailer. A recreational trailer is a trailer designed, adapted, and used exclusively for recreational purposes. This class includes boat, camping, livestock, and semi-trailers.
2. Utility Trailer. Any vehicle designed to be towed by a motor vehicle.
3. Boats, buses, snowmobiles, all terrain vehicles, sea-do's, jet skis are not permitted in the Bridleridge parking lot.
4. Commercial vehicles. Commercial vehicles are defined as those vehicles, including but not limited to, vehicles which have at least one of the following: commercial license plates; vehicles with external signage; vehicles equipped with a snow plow; vehicles with external storage rack systems for holding lumber, ladders, pipe, glass, or other implements and materials used in trades or businesses; etc.
5. Abandoned vehicles. Vehicles without proper state registration and/or proper license plate are considered abandoned vehicles. Vehicles that are inoperable and/or left on Bridleridge property for more than 30 days without being moved are considered abandoned vehicles.

16. NUISANCE

No owner or occupant of any Unit shall carry on, or permit to be carried on, any practice which unreasonably interferes with the quiet enjoyment and proper use of another Unit by the owner or occupant of any Unit, or which creates or results in a hazard or nuisance on the Property.

Nuisance complaints should be directed to Northampton Township Police Dept.

17. PAINTING

A. ACC request forms are required for exterior painting.

B. Those areas that are painted may be repainted; only those areas that are stained may be restained and unstained areas such as brick shall remain unpainted and unstained. The exception to this rule is as follows:

1. Exposed basement walls can be painted with masonry paint which matches the color of the exterior siding of the house. This is encouraged to enhance the aesthetics of the community. Prior approval by the ACC is required.

C. Capping of wood must match existing trim color. ACC request form must be submitted.

D. TOWNHOUSES IN BRIDLERIDGE

**Sherwin Williams Paints- 2050 S. Eagle Rd., Newtown, PA 18940, 215-579-2946 or
393 Easton Road, Warrington, PA, 215-491-2864**

DOORS #1

Doors = Village Shires Hampton Blue latex semi-gloss
Shutters = Tricorn Black SW6258 latex semi-gloss
Scallop, Rails & Trim = White latex semi-gloss

DOORS #2

Shutters & Doors = Village Shires Independence Red latex semi-gloss
Scallop trim = Village Shires Bridleridge Gray latex semi-gloss
Rails & Trim = White latex semi-gloss

DOORS #3

Shutters & Doors = Village Shires Green latex semi-gloss
Scallop trim = Village Shires Bridleridge Yellow/Gold latex semi-gloss
Rails & Trim = White latex semi-gloss

18. PARKING

A. Parking is permitted in designated parking spots only. Parallel parking is prohibited in order to allow a clear pathway for emergency vehicles.

B. No parking in fire lanes. For the safety of all concerned, vehicles parked in fire lanes are subject to immediate towing, without warning, at the Owner and/or tenant expense.

C. Obstructing roadways for fire and emergency vehicles is prohibited.

D. No parking is permitted on the street when the snow has reached a depth of two (2) inches or more and snow removal operations are in process. This regulation is in effect for a period not exceeding 72 hours after cessation of a snowfall.

E. Parked vehicles will not extend into the right-of-way and are subject to being towed.

F. No owner or lawful occupier will leave any non-operating vehicle or vehicle not licensed to be operated on or about the property of either the owner or the Association.

19. PATIOS, PATIO COVERS AND DECKS

A. Patios

1. ACC request forms are required with description and location
2. ACC Neighbor Notification Form with adjoining neighbors' signatures is required.
3. The township will only allow a specified percentage of your property to be covered by impervious construction. This is of particular importance to townhouse owners. Check with the township when planning a patio expansion. Block or brick construction only set in sand is not considered impervious construction but does require ACC Permission Request Form with the description, location and Neighbors Notification Form.

B. Patio Covers

1. ACC request form is required.
2. Structure materials used for the patio cover must be in keeping with those used on the existing house.
3. Patio cover must have a minimum roof pitch of three (3) inches per foot.
4. Roof shingles must match those on existing roof of the house.
5. The siding and trim must match that of existing home.

C. Ground Floor Decks in Townhouses

1. Decks must comply with Township Ordinance No. 298. Any variance from the requirements from Ordinance No. 298 must be approved by the Architectural Control Committee prior to the submission of a request for variance to the Northampton Township Zoning Board.
2. Skirting, if desired, shall not include lattice or metal fencing.
3. Railing, if desired, shall consist of 4" x 4" corner posts, 2" x 2" balusters and 2" x 4" or 2" x 6" top rails. The railing may be up to 36" in height.
4. Deck materials must be uniform and match in color, i.e. railings, deck boards, steps, etc.
5. Decks must be approved by Chairpersons Committee and Board of Directors.
6. Before submitting an ACC Request Form contact the Township for a deck package to be submitted along with the ACC Request Form.

20. PET POLICY

A. All pets must be leashed and accompanied by pet owner at all times unless inside a totally enclosed yard.

B. No pet will be permitted to run loose or uncontrolled in or on a neighbor's property and/or the Common Grounds.

C. There are no designated pet walk areas. Pet owners shall immediately clean up any waste left by pets and shall dispose of waste in owner's trash.

D. The tying of pets to trees or stakes on any Common Grounds is prohibited.

E. It is the responsibility of pet owners to keep their pets from scratching, digging, defecating or urinating upon any lawns, shrubs, plants, buildings on private property (excluding the property of the pet owner).

F. Complaints regarding violation of pet regulations must be in writing on a Pet Policy Complaint form. Complaint forms may be obtained from the VSCA office. The complaint must be filed within three days of occurrence.

G. Audible Disturbances. It shall be unlawful and is hereby declared to be a public nuisance in the township of Northampton for any person to keep, maintain or allow to be kept or maintained upon premises under control of such person any animal which creates or causes audible noise or sound, which is audible off the premises to such an extent that the sleep, rest, quiet and repose

of the residents of the community are disturbed or interrupted during the day or night. See Northampton Code Article I Dogs
H. See VSCA PET POLICY & NORTHAMPTON CODE ARTICLE I for further information, regulations and enforcement.

21. PROPANE TANK

A. Residents are permitted to have a propane fire unit that does not exceed 20 pounds.

22. PROPERTY MAINTENANCE

- A. Each Unit shall be maintained by its owner and/or occupant in a safe, clean and sanitary manner and condition, in good order and repair and in accordance with all applicable restrictions, conditions, ordinances, codes and any rules or regulations as may be applicable hereunder or under law.
- B. Grass areas shall be mowed so that the grass height does not exceed six (6) inches or go to seed.
- C. Yards and homes shall be maintained to provide a neat appearance to the development.
- D. All Residents must maintain ground cover on their lots to avoid erosion into the streets or other properties.
- E. Residents will avoid conditions which may cause health risks in the community.
- F. Sidewalks must be maintained so that they are free of trip hazards. Badly spalled conditions must also be properly repaired or replaced.
- G. All doors, shutters, scallops, rails, trim and cladding must be maintained in good order and kept neat in appearance. Painting is to be done in the approved color for your building (see item 17-Paint).
- H. Roofs should have no visible signs of missing shingles or any type of cladding.
- I. Units should reasonably be kept clean of mildew, including roofs.

23. ROOF & ROOF MAINTENANCE - ACC REQUEST FORMS ARE REQUIRED

- A. In order to maintain the architectural design of the buildings, roofing materials which do not match the existing roof will not be permitted. If a leak develops and matching roofing materials are not available, a homeowner may be required to replace shingles on the entire roof, including pent roofs, in order to maintain a uniform appearance.
- B. Bridleridge Roofs: GAF Timberline Williamsburg Slate

24. SATELLITE DISHES

- A. Refer to the separate published guidelines available in the VSCA office.
- B. ACC request form is required.

25. SHEDS

The erecting of sheds is discouraged so as not to obstruct the view of the surrounding neighbors and detract from the community. Application request for sheds shall provide justification for the need of outside storage, show the exact placement on the property (which must sit behind the rear building wall and which may not extend beyond an imaginary sight line along the side of the building from the front outside edge to the back outside edge. This is to ensure that the shed will not be visible from the street), include a description of the construction plans and have adjacent neighbor's signatures on the ACC Neighbor Notification form. All shed requests must be approved by the ACC Committee and also by the Board of Directors.

- A. Interior units are **NOT** permitted to erect a shed.
- B. End units must follow shed construction. The shed shall not exceed 8' x 8' x 8'. (Height is measured from the ground to the highest point).
- C. SHED CONSTRUCTION

1. A concrete pad or township approved concrete footer (circular) is suggested but not required. All foundations must meet township regulations and a building permit is required.

2. A dimensional sketch of your plot plan, clearly indicating the exact intended location and dimensions of the shed, must be attached to the ACC request form.
3. Barn type construction of wood, wood covered with aluminum or vinyl siding, or molded resin to conform with the main building.
4. Shall be the same color of the home.
5. Shingles to match the color of the roof.
6. Dimensions shall not exceed 8' x 8' x 8'. Height is measured from the ground to the highest point.
7. A permanent floor is mandatory.
8. Placement of the shed must be behind the back wall of the house and conform to the Township requirements.
9. All sheds shall not be visible from the line of sight of the street of your Unit. See Figure below.
10. All sheds must be secured per manufacturer specifications and instructions.

D. MOLDED PLASTIC RUBBERMAID TYPE STORAGE BINS (temporary structures)

1. Allowed on all properties
2. Maximum size 5' wide, 2.5' deep, 4' high
3. Application requests shall provide justification for the need of outside storage, show the exact placement on the property (which must sit behind the real building wall and which may not extend beyond an imaginary sight line along the side of the building from the front outside edge to the back outside edge. This will ensure that the storage bin will not be visible from the street if you are an end unit) include a description of the plans and have adjacent neighbor's signatures on the ACC Neighbor Notification form. All requests must be approved by the Chairpersons Committee and the Board of Directors.
4. The approved color = earth tones.
5. No more than one (1) unit per home is permitted.

26. SIDING- ACC REQUEST FORMS ARE REQUIRED

A. Siding must present a uniform appearance. Even replacing the siding with the identical materials in most cases will not present a uniform appearance because of fading and other environmental effects on the existing siding. Therefore, when a section of siding has been damaged, has blown off, or otherwise requires replacement, it is necessary to replace siding on the entire exterior structure of the unit on all sides to ensure uniform appearance. The siding is Double 4 woodgrain clapboard.

EXISTING COLOR SIDING

White
Gold
Gray

NEW SIDING COLOR

White by Mastic
Autumn Yellow by Certainteed
Sterling Gray by Certainteed

27. SKYLIGHTS

A. Flat skylight(s) are allowed and the location shall be determined by majority of owners in each building, as to whether they will be located on the front or rear roof. All units in the building must be notified. The majority of unit owners must sign the ACC Neighbor Notification form and submit it with the Permission Request form.

B. Skylight(s) may be fixed or movable.

C. Skylight(s) must not exceed 5% of the roof area.

28. SIDEWALKS:

Homeowners must maintain the section of sidewalk that leads up to the home and in front of the home. Unacceptable conditions include: tripping hazards, displacements of over 1/2 inch "out of level", large cracks over 1/2 inch in depth and 3 inches in diameter, spalled (deteriorated surface) concrete, and/or displaced curbs with poor drainage. **Drawing or sketch must be submitted with all ACC requests for work on sidewalks.**

29. STEPS/RAILINGS:

The homeowner is responsible for any repairs or replacement to steps due to spalling or deterioration of concrete (same as above). Steps have to meet the concrete. When replacing the railing, it has to be the same style and color.

In general, repairs do not last and concrete replacement should be considered. Materials used to repair spalling or cracked concrete must be applied to maintain a uniform and neat appearance of the entire surface, end to end, front to back. If there is a repair to a step, the whole step must be repaired – no patches.

30. SWING SETS, SLIDES, RECREATIONAL STRUCTURES, SPAS, POOLS

A. Swing sets, slides, and recreational structures of any type are not permitted.

B. Spas, hot tubs and pools are not permitted.

31. TRASH

A. No portion of the property shall be used or maintained as a dumping ground for rubbish, trash, new or used lumber or wood, metal scrap, garbage or other waste.

B. Trash will not be put out at curbside before 6:00 p.m. on the evening prior to the appointed pick-up days. All trash receptacles must be put away by 8:00 a.m. the morning after the trash has been picked up.

C. Household trash must be in a trash can or trash bag which is tied. Between pick-ups, all trash and recyclable bins, bags, cans & containers shall be kept out of the site line from the street and shall not be visible from the street or stored on the front porch.

D. All trash and household refuse shall be kept in covered cans or tied plastic trash bags. Trash and household refuse shall not be kept in paper bags. Untied or unbagged newspapers are prohibited.

E. See VSCA trash policy for your scheduled trash, recycle, yard waste/leave and bulk item pick-up days.

F. Bulk rubbish that is in excess of the Northampton Township bulk rubbish removal policy must not be put out at curbside. The NHTWP bulk rubbish removal policy states that "One bulk item may be put out each week on the second collection day. Carpets must be cut into three to four foot widths, rolled up, and tied or taped. Up to 10 rolls of carpet may be put out per collection. Note also that a special pick-up must be arranged for items that contain freon, such as refrigerators, freezers, HVAC units, & dehumidifiers. Call Mascaro at 800-432-1616 for pick-up of such items. For the safety of children, please completely detach the doors from refrigerator units before you place them outside for trash pick-up.

32. WINDMILLS

Windmills are not permitted anywhere in the community.

33. WINDOW FLOWER BOXES

Flower boxes are permitted under windows. All boxes must be 48 inches wide, uniform black color, made of molded high grade polyethylene or other maintenance-free plastic.

34. WINDOWS, DOORS AND SCREENS

A. ACC Permission Request Forms are required.

B. Storm doors are permitted. Storm door and storm door grills must match approved color of front door.

C. All window replacements must be as follows:

1. The replacement window may be vinyl, aluminum, and wood or clad.
2. The replacement window must be the same style and appearance.
3. The replacement window must be white with white window grills.
4. The replacement window must be double hung.

D. Patio Doors:

1. The replacement door must be the same style and appearance.
2. French doors and grills are permitted.
3. The exterior must be white.

35. WINDOW AIR CONDITIONERS AND WINDOW FANS

Window air conditioners are prohibited.

36. WOOD STOVES

- A. ACC approval is not required if an external chimney already exists.
- B. Township permits are required and are the responsibility of the owner. Send a copy of permit to the VSCA office. It will remain on file.